



The soul of ceramic

AUREO
Radiators



Voices: the soul of ceramic is the new project by Terratinta Group that combines thin slabs, bathroom furniture, thermo-structured panels and shower trays to offer a complete and flexible project to customize bathroom spaces.

With Voices, Terratinta Group offers a selection of floors and walls inspired by music. From the elegance of the opera to the liveliness of rock, crossing through the virtuosity of blues and jazz, the Voices project reflects the musical vocalization through different styles that combine material and color, finishes and geometries, with a reverberation that refers to four interpretations of modern bathroom.

The synergy created by Terratinta Group with Studio Lucchese, Arbi Arredobagno and Fir Italia, realities of experience in their sectors, is the harmonious background on which to build a new symphony.

Voices: the soul of ceramic è il nuovo progetto di Terratinta Group che unisce lastre di spessore sottile, elementi di arredobagno, termoarredo e piatti doccia per offrire un progetto completo e flessibile per la personalizzazione degli spazi bagno.

Terratinta Group propone con Voices una selezione di pavimenti e rivestimenti ispirati alla musica.

Dall'eleganza dell'opera alla vivacità del rock, passando attraverso i virtuosismi del blues e del jazz, il progetto Voices riflette i vocalizzi musicali attraverso stili diversi che accostano materia e colore, finiture e geometrie, con un riverbero che rimanda a quattro modi di interpretare il bagno oggi.

La sinergia creata da Terratinta Group con Studio Lucchese, Arbi Arredobagno e Fir Italia, realtà d'esperienza nei propri settori, è il sottofondo armonioso su cui costruire una sinfonia nuova.

AUREO RADIATOR
TERMOARREDI AUREO

General features / Caratteristiche generali

PRODUCT

Thanks to its heating system, the termodesign Electric System allows to heat the environment by thermal radiation, emitting long-wave infrared very similar to the rays emitted by the sun, which are perceived by the human body creating a condition of well-being. This advanced system also allows you to directly heat the elements in the room which in turn re-emit their heat within the environment.

The Electric System termodesigns boast a latest generation touch screen control system that allows, in combination with the remote control, to optimize performance.

The daily and weekly chronothermostat allows to program the switching on and off for a flexible heating and the most suitable for the user's needs. The three pre-set temperature modes allow you to select the best suited heating mode based on the size of the room and the temperature, thus avoiding energy waste.

TECHNICAL DATA

The construction of the Electric System termodesign involves the use of a 0.4 cm double tempered glass and an adhesive plastic film (Eyebeam standard) which, in case of breakage, allow safety performance at B1 level according to **European standard UNI 12600** with performance equal to that of a shatterproof laminated glass.

> The cable length, equipped with a Schuko plug, is 1,25 m.

MATERIALS THICKNESS

For Aureo model >

Terratinta Group porcelain stoneware 0,6 + glass 0,4 cm

SUSTAINABILITY

The fabrication of the Electric System termodesign complies with the provisions of the **Ecodesign Directive 2009/125/EC** and of the **EU Regulation 2015/1188** relating to environmental heating appliances.

SAFETY

The construction of the termodesign allows safety performance at B1 level according to the European standard UNI 12600. The assembly guarantees the isolation of the electronics in class 2 and an IP 45 protection level, thus ensuring maximum safety even in wet environments, such as bathrooms, swimming pools, saunas, etc. The specially designed brackets prevent the inadvertent release, in accordance with the **German VDE 6036 safety regulation for radiators**, once the product has been installed. The termodesigns are also equipped with various safety devices: in case of overheating of the plate, the electronic board immediately puts the radiator on stand-by. If the action of the board is not enough, the device is equipped with a double safety sensor that records the surface temperature and immediately blocks it.

REMOTE CONTROL

All Electric System termodesigns are equipped with a remote control, with LCD display, which also acts as a thermostat. The remote control allows you to adjust the room temperature and set different operating programs.

CERTIFICATIONS

- > EN 55014-1: 2006 + A1:2009 + A2:2011
- > EN 61000-3-2:2006 + A1:2009+A2:2009
- > EN 61000-3-3:2013
- > EN 55014-2:1997 + A1:2001+A2:2008
- > EN 62233:2008
- > EN 60335-1:2012
- > EN 60335-1:2012 + AC:2014+A11:2014
- > EN 50564:2012
- > EN 60335-2-30: 2009 + A11:2012

Please note: the choice of size and power of the radiator is to be evaluated based on energy demand. For a correct evaluation it is necessary to contact your heating technician.

IL PRODOTTO

Grazie al suo sistema di riscaldamento, il termodesign Electric System permette di scaldare l'ambiente per irraggiamento, emettendo infrarossi a onda lunga molto simili ai raggi emessi dal sole, che vengono percepiti dal corpo umano creando una condizione di benessere. Questo avanzato sistema permette inoltre di scaldare direttamente gli elementi presenti nella stanza che a loro volta riemettono il loro calore all'interno dell'ambiente.

I termodesign Electric System vantano un sistema di controllo touch screen di ultima generazione che consente in combinazione con il telecomando di ottimizzare al meglio le prestazioni.

Il cronotermostato giornaliero e settimanale permette di programmare l'accensione e lo spegnimento per un riscaldamento flessibile e il più adatto possibile alle esigenze dell'utilizzatore. Le tre modalità di temperatura preimpostate permettono di selezionare in base alla dimensione dell'ambiente e alla temperatura che si desidera ottenere la modalità di riscaldamento più adatta alla situazione, evitando sprechi energetici.

DATI TECNICI

La costruzione dei termodesign Electric System prevede l'utilizzo di un doppio vetro temperato da 0,4 cm e di un film plastico adesivo (per Eyebeam standard) che, in caso di rottura, consentono prestazioni di sicurezza a livello B1 secondo **normativa europea UNI 12600** con prestazioni pari a quelle di un vetro laminato antisfondamento.

> La lunghezza del cavo, dotato di spina Schuko, è di 1,25 m.

SPESSORI MATERIALI

Per modello Aureo > Gres porcellanato Terratinta Group 0,6 + vetro 0,4 cm

ECOSOSTENIBILITÀ

La costruzione dei termodesign Electric System rispetta quanto previsto dalla direttiva **Ecodesign 2009/125/CE** e del **Regolamento UE 2015/1188** relativamente agli apparecchi di riscaldamento d'ambiente.

SICUREZZA

La costruzione dei termodesign consente prestazioni di sicurezza a livello B1 secondo la normativa europea UNI 12600. L'assemblaggio garantisce un livello di isolamento delle elettroniche in classe 2 e un livello di protezione IP 45 garantendo così la massima sicurezza anche in ambienti umidi, quali bagni, piscine, saune, ecc. Gli staffaggi appositamente progettati impediscono, una volta installato il prodotto, lo sganciamento inavvertito, in accordo con la **normativa tedesca VDE 6036 di sicurezza dei radiatori**. I termodesign sono inoltre dotati di svariati dispositivi di sicurezza: in caso di surriscaldamento della piastra la scheda elettronica manda immediatamente il termoarredo in stand-by. Se l'azione della scheda non dovesse bastare il dispositivo è dotato di un doppio sensore di sicurezza che ne registra la temperatura superficiale mandandolo immediatamente in blocco.

TELECOMANDO

Tutti i termodesign Electric System sono forniti di un telecomando, con display LCD, che funge anche da termostato. Il telecomando permette di regolare la temperatura dell'ambiente e di impostare diversi programmi di funzionamento.

CERTIFICAZIONI

- > EN 55014-1: 2006 + A1:2009 + A2:2011
- > EN 61000-3-2:2006 + A1:2009+A2:2009
- > EN 61000-3-3:2013
- > EN 55014-2:1997 + A1:2001+A2:2008
- > EN 62233:2008
- > EN 60335-1:2012
- > EN 60335-1:2012 + AC:2014+A11:2014
- > EN 50564:2012
- > EN 60335-2-30: 2009 + A11:2012

Attenzione: la scelta della dimensione e della potenza del termoarredo è da valutare in base al fabbisogno energetico dell'abitazione. Per avere la valutazione corretta è necessario rivolgersi al proprio termotecnico.

RADIATOR'S SECTION (in glass) / SEZIONE TERMOARREDO (in vetro)

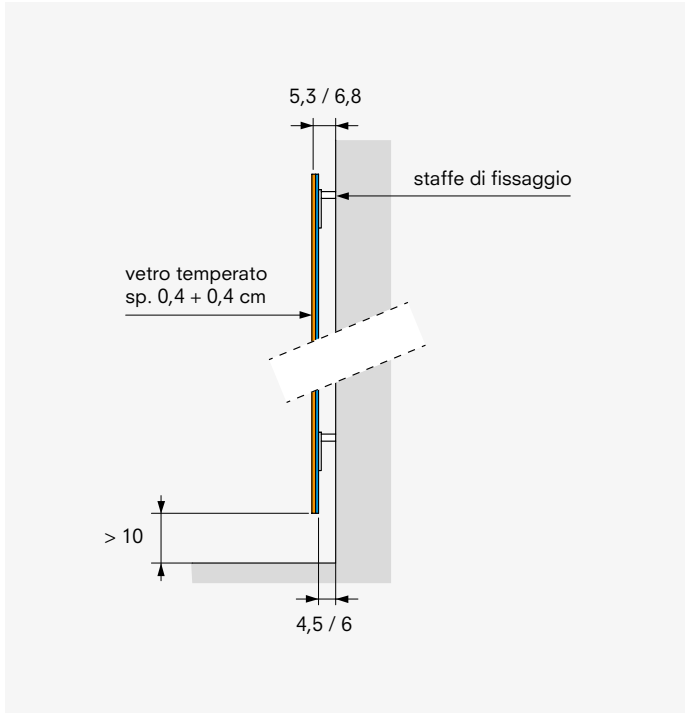

WELL-BEING
BENESSERE



SUSTAINABILITY
ECOSOSTENIBILITÀ



TOUCH SCREEN
CONTROL
REGOLAZIONE
TOUCH SCREEN



ELECTRIC
SYSTEM
SISTEMA
ELETTRICO



Aureo

RADIATOR CHARACTERISTICS

- Porcelain stoneware finishes
- Porcelain stoneware thickness **0,6 cm**
- Sizes: slim, small e medium
- Remote control included in the price
- Integrated touch keypad, fixed position on the right

(See pages 57 and 58 for technical drawings)

CARATTERISTICHE TERMOARREDO

- *Finiture gres porcellanato*
- *Spessore gres porcellanato 0,6 cm*
- *Misure: slim, small e medium*
- *Telecomando incluso nel prezzo*
- *Tastiera touch integrata, posizione fissa a dx*

(Vedi pag. 57 e 58 per disegni tecnici)

SLIM

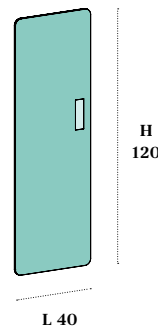

SMALL

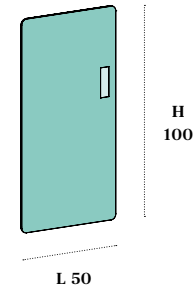

MEDIUM

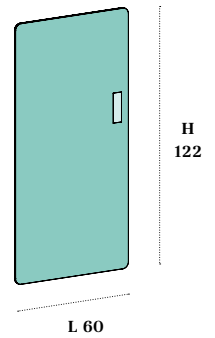

AVAILABLE SIZES / MISURE DISPONIBILI

ITEM / ARTICOLO	SIZES / DIMENSIONI	POWER / POTENZA	Kg
T001	slim	500 watt	11,2
T002	small	700 watt	11,8
T003	medium	1000 watt	16,7

These materials are available in 14 different finishes shown in the following page.

Questi materiali sono disponibili in 14 differenti finiture visionabili nella pagina seguente.

ACCESSORIES / ACCESSORI

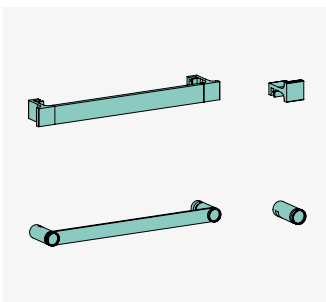

Towel rail and hangers can match the radiators.

See page 59 and following.

Portasalviette e appendini abbinabili ai termoarredi.

Vedi pagina 59 e successive.

Porcelain stoneware FINISHES / FINITURE gres porcellanato

Thickness 0,6 cm / Spessore 0,6 cm

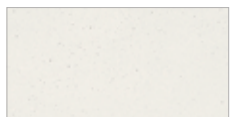

Terratinta
Kos VIT matt



Terratinta
Kos SAND matt



Terratinta
Kos BRUN matt

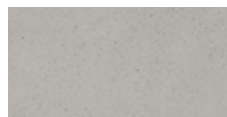

Terratinta
Kos MOLN matt



Terratinta
Kos ANTRACIT matt

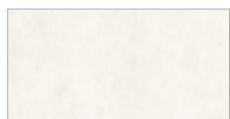

Terratinta
Betontech WHITE matt

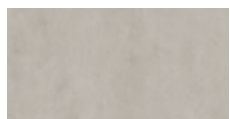

Terratinta
Betontech GREY matt



Terratinta
Vicentina CENERE matt



Ceramica Magica
Marmo CARRARA polished

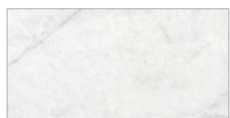

Ceramica Magica
Marmo CARRARA silk



Ceramica Magica
Marmo APUANO honed



Ceramica Magica
Arte Marmo GREY polished



Ceramica Magica
Arte Marmo GREY silk



Ceramica Magica
Ceppo GREY matt

NOTE: for the real correspondence of the finishes, please use as reference the samples.
ATTENZIONE: per la reale corrispondenza delle finiture fare riferimento al campionario.

TECHNICAL DRAWINGS / DISEGNI TECNICI

SLIM

FRONT/FRONTE

BACK/RETRO

SIDE/LATO

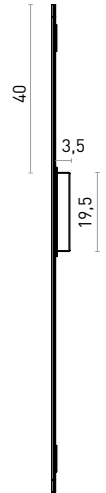
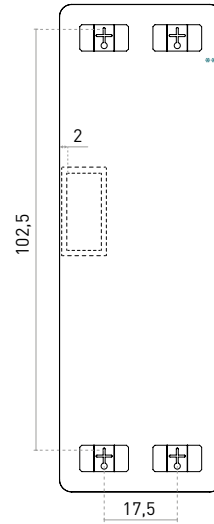
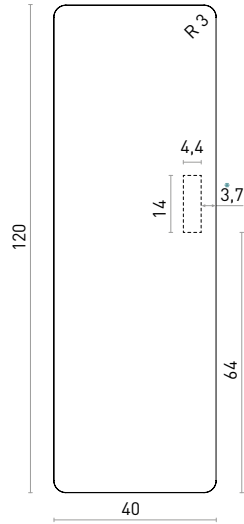
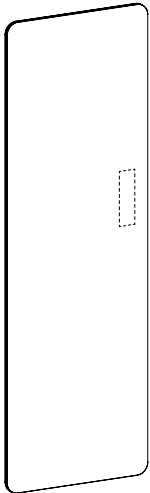

* touch keypad/tastiera touch

** hanger for wall mounting
aggancio per fissaggio a muro

SMALL

FRONT/FRONTE

BACK/RETRO

SIDE/LATO

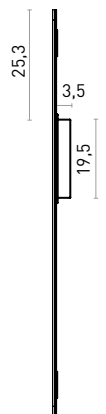
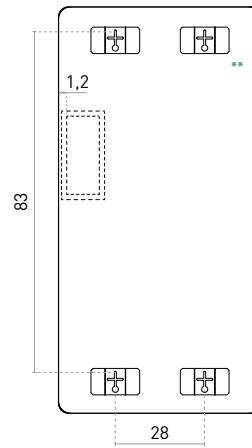
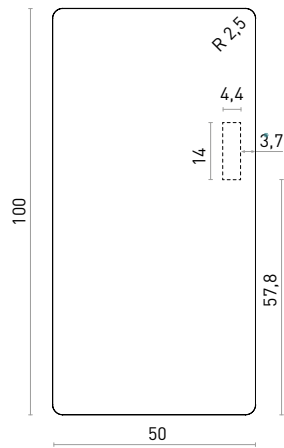
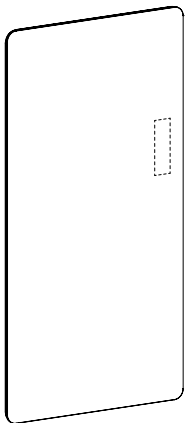

* touch keypad/tastiera touch

** hanger for wall mounting
aggancio per fissaggio a muro

TECHNICAL DRAWINGS / DISEGNI TECNICI

MEDIUM

FRONT/FRONTE

BACK/RETRO

SIDE/LATO

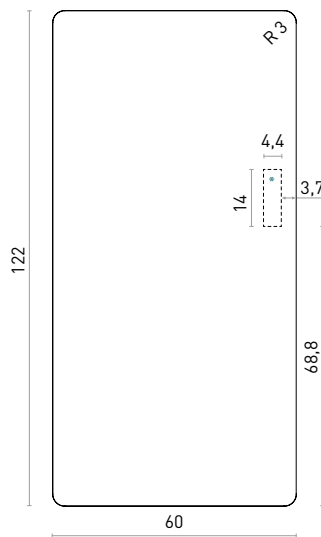
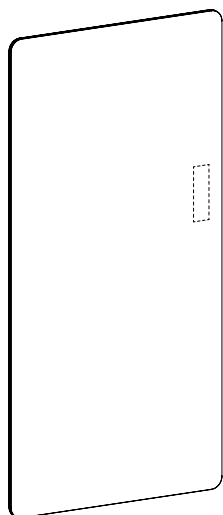

* touch keypad/tastiera touch

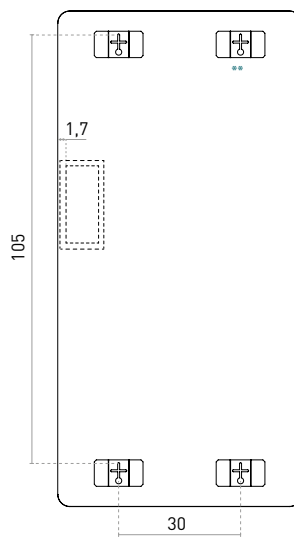

** hanger for wall mounting
aggancio per fissaggio a muro

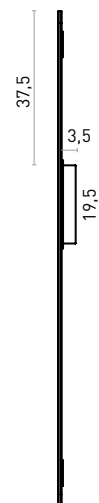

TOUCH KEYPAD TASTIERA TOUCH

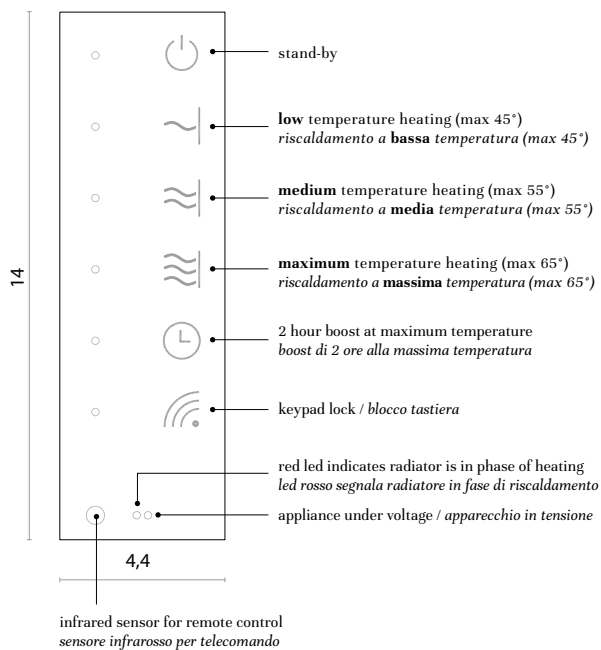

RADIATOR ACCESSORIES
ACCESSORI PER TERMOARREDO

Chronos

	ITEM/ART.	DRAWING/DISEGNO	AVAILABLE ON UTILIZZABILE SU
TOWEL RAIL Black / Bronze PORTASALVIETTE Nero / Bronzo	A491 > rod with finish <i>tondino con finitura</i>		radiator/termoarredo slim
	A495 > empty rod <i>tondino vuoto</i>		
	A492 > rod with finish <i>tondino con finitura</i>		radiator/termoarredo small
	A496 > empty rod <i>tondino vuoto</i>		
	A493 > rod with finish <i>tondino con finitura</i>		radiator/termoarredo medium
A497 > empty rod <i>tondino vuoto</i>			
HANGER Black / Bronze APPENDINO Nero / Bronzo	A494 > rod with finish <i>tondino con finitura</i>		all radiators <i>tutti i termoarredi</i>
A498 > empty rod <i>tondino vuoto</i>			

N.B. Accessories can be arranged as needed
 N.B. Gli accessori sono posizionabili a piacimento

FINISHES / FINITURE



610 black/nero



268 bronze matt/bronzo opaco



* NOTE: for Aureo porcelain stoneware radiator, the finish inside the rod will be standardized the same one chosen for the radiator.

* ATTENZIONE: nel caso del termoarredo Aureo la finitura interna al tondino sarà, di serie, uguale a quella del termoarredo ordinato.





—above
Chronos hanger detail
in matt bronze finish.

—sopra
*Dettaglio appendino Chronos
in finitura bronzo opaco.*

Zeus

ITEM/ART.	DRAWING/DISEGNO	AVAILABLE ON UTILIZZABILE SU
TOWEL RAIL Inox / Black brushed PORTASALVIETTE Inox / Nero spazzolato		radiator/termoarredo slim
A488		radiator/termoarredo small
A489		radiator/termoarredo medium
HANGER Inox / Black brushed APPENDINO Inox / Nero spazzolato		all radiators tutti i termoarredi

N.B. Accessories can be arranged as needed
 N.B. Gli accessori sono posizionabili a piacimento

FINISHES / FINITURE



INX inox brushed
 inox spazzolato



267 black brushed
 nero spazzolato



"Stay hungry, stay foolish."

S. Jobs 1955-2011

in collaborazione con:

ARBI
BATHROOM



PROJECT BY TERRATINTA MKTG LAB
PRINTED IN ITALY, **September 2020**
TERRATINTA CERAMICHE ALL RIGHTS RESERVED

C
H
A
N
G
E

WE CAN
CHANGE
HABITS
**NOT OUR
PLANET**

BY
TERRATINTA
group





A BRAND of TERRATINTAGROUP
Via Monte Bianco 55 - 41042 Fiorano Modenese
(MO) Italy | Tel. +39 0536911408
www.atmosfere.design